

Dr.-Ing. Thomas Weinzierl
Weinzierl Engineering GmbH

KNX-RF Implementation based on MSP430 and CC1101

Abstract

KNX is a standard for home and building electronic systems including wireless communication named KNX-RF (KNX radio frequency). This application note gives an overview about the KNX standard, the technical properties and hardware solutions based on Texas Instruments components MSP430 and CC1101 for bidirectional devices and CC1150 for unidirectional devices.

1 Application area

The focus of the KNX standard (former EIB/Konnex) is home and building control. The most typical application areas are lighting, shutters or heating and cooling. KNX has been ratified as European (EN 50090) and world-wide (ISO/IEC 14543-3-x) standard for home and building electronic systems. The standard covers the wired media twisted pair, power line and Ethernet. In locations not suitable for cabling, KNX-RF is used for wireless data transmission within a building. As the complete KNX standard also the wireless part KNX-RF is vendor independent. The configuration of KNX-RF networks can be done with or without using a PC or a laptop.

2 Protocol

2.1 Addressing scheme

The addressing scheme is based on the system architecture used for twisted pair, which uses individual addresses and group addresses (each 2 bytes). The individual address is a single cast address and is mainly used for configuration purpose. Group addresses are used for runtime communication. The group address 0x0000 is reserved as broadcast address.

As RF is an open medium like powerline, a domain address (6 byte, programmable) has been added to separate different neighbouring installations. Unidirectional devices can not be programmed and therefore are not able to use an installation specific domain address. So group telegrams contain the serial number of the sender instead. The serial number together with the 2 byte group address is called an extended group address. The following addressing modes are defined for KNX-RF:

1. Part of address (6 Bytes)	2. Part of address (2 Bytes)	Resulting addressing mode
Serial number	Group address	Multicast
Domain address	Group address 0x0000	Broadcast inside domain
Domain address	Individual address	Singlecast inside domain
Serial number	Group address 0x0000	System Broadcast, all domains

Addressing modes in KNX-RF

Whereas in twisted pair and powerline the sender as well as the receiver has to be programmed to build a link, in KNX-RF only the receiver has to be configured.

2.2 Physical Layer

The physical layer of KNX-RF is specified according to the regulations for short range devices.

Technical data for KNX-RF:

- Centre frequency: 868.3 MHz
- FSK Deviation: +-50 kHz
- Transmission power: 1-25 mW
- Duty cycle: 1 %
- Modulation: FSK
- Coding: Manchester
- Chip rate: 32.768 cps

The medium of KNX-RF is very reliable. The used frequency band is not as noisy as the alternative frequencies (e.g. 433 MHz). Compared to the new band in 2.4 GHz devices using 868 MHz show a better transmission behaviour within buildings.

2.3 Link Layer

The frame format of KNX-RF consists of multiple elements. Each telegram starts with a pre-header, which is used for the synchronisation of the receiver.

Preheader		
Preamble	Manchester violation	Sync word
15x '01' chip	'000111'	'011010010110'

KNX-RF pre-header

After the pre-header the first data block follows with some control information and the serial number or the domain address. The first block has a fixed length of 10 data bytes and an own checksum of 2 bytes.

Block 1											
Length	C-Field	Esc	Ctrl	SN	SN	SN	SN	SN	SN	CRC hi	CRC lo
0x11	0x44	0xFF	0x03								

KNX-RF data block 1

The application data starts in block 2, which has a maximum length of 16 byte plus 2 bytes checksum. For longer telegrams additional blocks may follow. The coding of the data in block 2 and following are according the telegram format used for twisted pair and for powerline.

Block 2											
KNX-Ctrl	Src hi	Src lo	Dst hi	Dst lo	L/NPCI	TPCI	APCI	Data	...	CRC hi	CRC lo
0x00	0x05	0xFF	0x00	0x01	0xE6	0x00	0x81				

KNX-RF data block 2

It is remarkable that each block contains a separate checksum. The used polynomial achieves a hamming distance of 6. Although processing of received data is time-critical due to the relatively high data rate, it is still possible to detect and correct individual bit errors during reception. Consequently, communication quality is very high even when transmission conditions are unfavourable. Assumed a bit error rate BER (here chip error rate) of 10^{-4} the error correction improves telegram success rate from 96.31 % to 99.97 %.

2.4 Network Layer

The network layer for end devices (sensors and actuators) is quite simple. In the receiving direction the network layer only interprets the addressing mode. In the sending direction it builds the link layer request for all kind of frames to be sent. If a device supports retransmission of frames, this functionality it implemented also in the network layer.

2.5 Transport Layer

For KNX-RF only connection-less communication is used. The connection-oriented communication like it is used for management purpose in twisted pair or powerline installations is not foreseen for the wireless medium.

2.6 Session und Presentation Layer

Like for twisted pair and powerline also for KNX-RF session and presentation layer are not defined. The corresponding services according to the OSI/ISO reference model have been moved to the application layer.

2.7 Application Layer

The application layer is split in a part for the runtime communication and the device management. The runtime communication uses only the following APCI service (Application Protocol Control Information):

- APCI_VALUE_WRITE

The complex management for KNX-RF used by bi-directional devices includes much more services:

- APCI_PHYS_ADDR_WRITE
- APCI_PHYS_ADDR_READ
- APCI_PHYS_ADDR_RESP
- APCI_PHYS_ADDR_SER_NUM_READ
- APCI_PHYS_ADDR_SER_NUM_WRITE
- APCI_PHYS_ADDR_SER_NUM_RESP
- APCI_DOMAINADDRESS_WRITE
- APCI_DOMAINADDRESS_READ
- APCI_DOMAINADDRESS_SER_NUM_WRITE
- APCI_DOMAINADDRESS_SER_NUM_READ
- APCI_DOMAINADDRESS_SER_NUM_RESP
- APCI_NETWORK_PARAM_WRITE
- APCI_DEVICE_DESC_READ
- APCI_DEVICE_DESC_RESP
- APCI_PROP_VALUE_READ
- APCI_PROP_VALUE_RESP
- APCI_PROP_VALUE_WRITE
- APCI_PROP_DESC_READ
- APCI_PROP_DESC_RESP
- APCI_FNCT_PROP_CMD
- APCI_FNCT_PROP_STATE_READ
- APCI_FNCT_PROP_STATE_RESP

This leads to a quite complex software implementation of bi-directional devices. Against this the code size of unidirectional devices is strongly reduced, as these devices do not need to handle all these services. More information about application layer services can be found in the KNX specification.

3 Configuration Modes

KNX defines not only different media, but also different configuration modes. For KNX-RF mainly the easy mode is used, but the system mode is mandatory for all devices.

3.1 System Mode (S-Mode)

The system mode describes the configuration process using a PC. Because of the very powerful user interface of a PC this mode offers the best possibilities to configure a system. Because of the complexity of the system mode, it is foreseen for professional installers. As all currently available devices are prepared for s-mode, it will be only a question of time for the release of an appropriate software tool. So it has been started to implement the KNX-RF support into the ETS (Tool Software for commissioning KNX installation).

3.2 Easy Mode (E-Mode)

The goal of the easy mode is the network configuration without using a PC. A product database like it is used for ETS is not necessary. All information needed to program a communication partner is stored in the devices. The easy mode configuration is divided into several sub modes. For small installations with KNX-RF the push button mode is the most common solution.

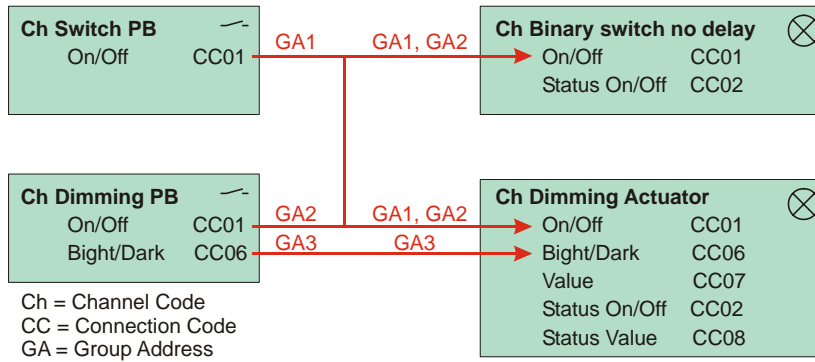

Example of an easy mode installation

The functions of a device are mapped to so-called KNX easy channels which can be linked by activating the learning mode of corresponding channels via push buttons or a similar human interface.

4 Hardware-Architecture

In low-cost solutions the microcontroller fulfils usually the communication tasks as well as the application. For the communication the microcontroller configures the RF chip via the programming interface and exchanges RF data via the data interface.

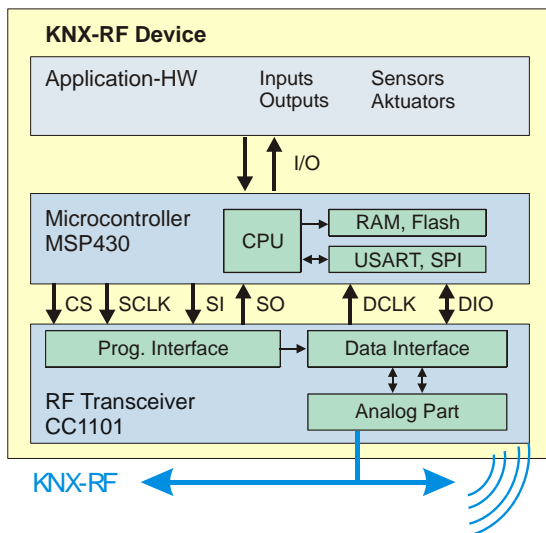

Typical hardware architecture for KNX-RF

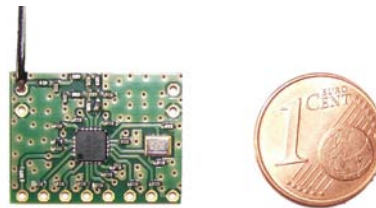

KNX-RF Module with CC1101

4.1 Components

The KNX-RF standard can be implemented in an effective way with components from Texas Instruments. The microcontroller family MSP430 offers different derivatives suitable for KNX-RF. Because of their low power consumption this family is optimal for battery driven wireless applications. For the RF interface the Chipcon products from Texas Instruments are very good suitable.

As RF front-end the CC1101 is an easy to use solution for bidirectional devices. For transmit only devices the CC1150 is available.

	Microcontroller	RF front-end
KNX bidirectional devices	MSP430 derivatives with > 20 kBytes Flash > 1 kBytes RAM e.g. MSP430F2370 or F2274	Transceiver CC1101
KNX unidirectional devices	MSP430 derivatives with > 4 kBytes Flash > 256 Bytes RAM e.g. MSP430F2121	Transmitter CC1150

Usage of components

The choice of the optimal microcontroller depends on application requirement. Of course also the derivatives with LCD controller can be used for KNX-RF implementations.

With this combination it is possible to produce powerful wireless devices with low costs and low power consumption. Especially unidirectional devices can be realized at a very low cost level.

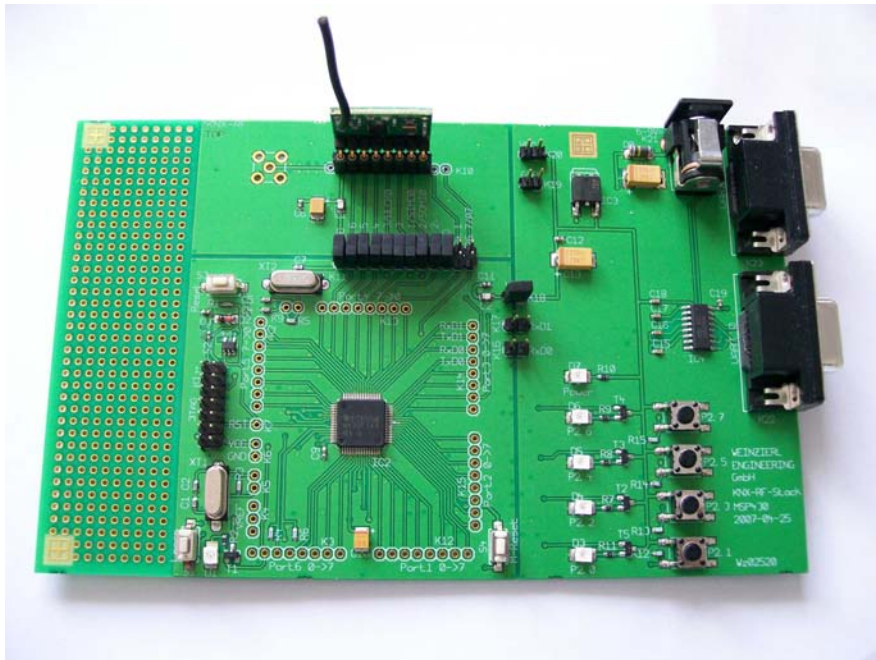

Development board for KNX-RF (MSP430 & Module with CC1101)

4.2 Configuration Interface

The CC1101/CC1150 are configured via a simple 4-wire SPI compatible interface (SI, SO, SCLK and CSn) where RF chip is the slave. All address and data transfer on the SPI interface is done most significant bit first. All transactions on the SPI interface start with a header byte containing a read/write bit, a burst access bit and a 6-bit address. During address and data transfer, the CSn pin (Chip Select, active low) must be kept low. The 4-wire interface could be connected to an on-chip USART in synchronous mode, configured as master. For most applications it is more useful to realize this interface via standard I/O pins and to save the USART for the data interface.

The register settings for KNX-RF can be found using the Smart RF Studio available from TI.

4.3 Data Interface

The CC1101/CC1150 chips have included a packet handler. But because of the different structure of the KNX-RF frames the packet handler can not be used. So the chips have to be used in synchronous serial operation. This means that the complete packet coding and decoding (inclusive Manchester code) has to be realized in the microcontroller.

As the CC1101/CC1150 has to be used in NRZ mode, the microcontroller has to send and receive the data bits in real time. To save calculation power it is recommended to use a USART in synchronous mode for sending and receiving. This is especially important for bidirectional devices. Send-only devices may use only standard I/O pins for communications. So even a microcontrollers without integrated USART might be used.

When using the USART at a chip rate of 32 768 cps specified for the KNX protocol, 4 096 patterns per second must be evaluated or sent. In receive mode the patterns sampled by the USART are not synchronized. So the software permanently has to scan for the start of frame.

4.4 Clock generation

The CC1101/CC1150 chips require an own crystal to generate the radio frequency and the bit timing. So the timing of the physical layer is completely controlled by the radio chip. To comply with the KNX Standard an over all accuracy of $\pm 35\text{ppm}$ must be achieved.

If there is no requirement for precise timing for the application task, the MSP430 can be clocked using DCO frequency. The required frequency depends on type of connection of RF chip (HW of SW UART) and on software efficiency.

4.5 Example Unidirectional

The following circuit shows an example circuit for a unidirectional node using MSP430F2121 and CC1150. For the interface between both chips only standard IO lines are used. The example is only a principle circuit without decoupling and application specific parts.

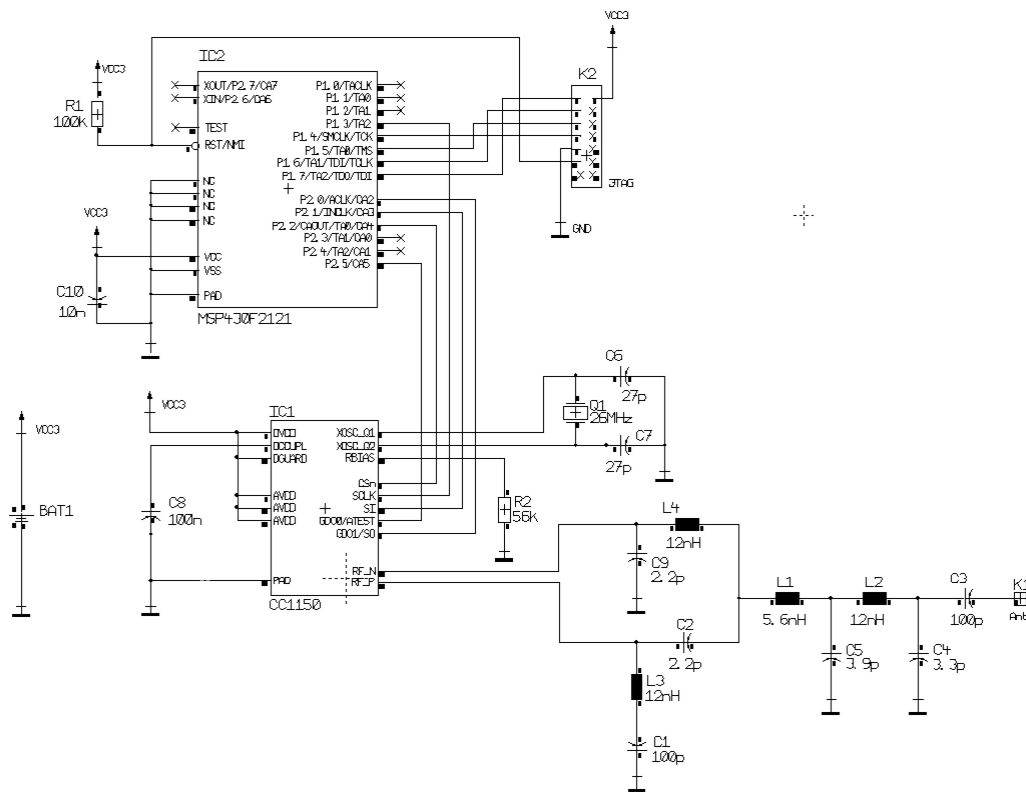

Example of unidirectional node

5 Stack-Implementation for KNX-RF

According to the KNX-RF standard, a stack implementation has to differentiate between unidirectional and bidirectional devices. Unidirectional devices contain only the send function and a highly simplified communication stack. The software supports a power save mode to lengthen battery life. Because the unidirectional software has a code size of only a few kBytes, very inexpensive controllers can be used.

A bidirectional implementation has both a sender and a receiver. Although processing of received data is time-critical due to the relatively high data rate, it is still possible to detect and correct individual bit errors during reception. Consequently, communication quality is very high even when transmission conditions are unfavourable. Bidirectional devices require a complete communication stack that also includes the link mechanism for putting the device into operation.

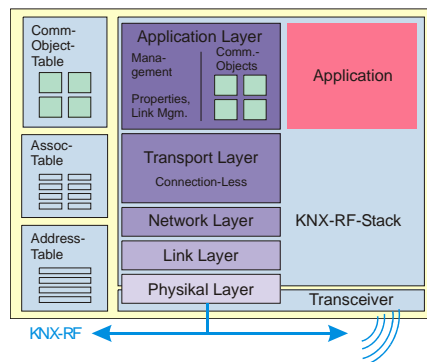

KNX-RF stack architecture

KNX stack implementations are available from Weinzierl Engineering GmbH, a member of KNX Association.

6 Development tools for KNX

Reliable tools are essential for effective development and for troubleshooting in existing systems. Weinzierl Engineering has extended the KNX analysis software *Net'n Node* for use with KNX-RF.

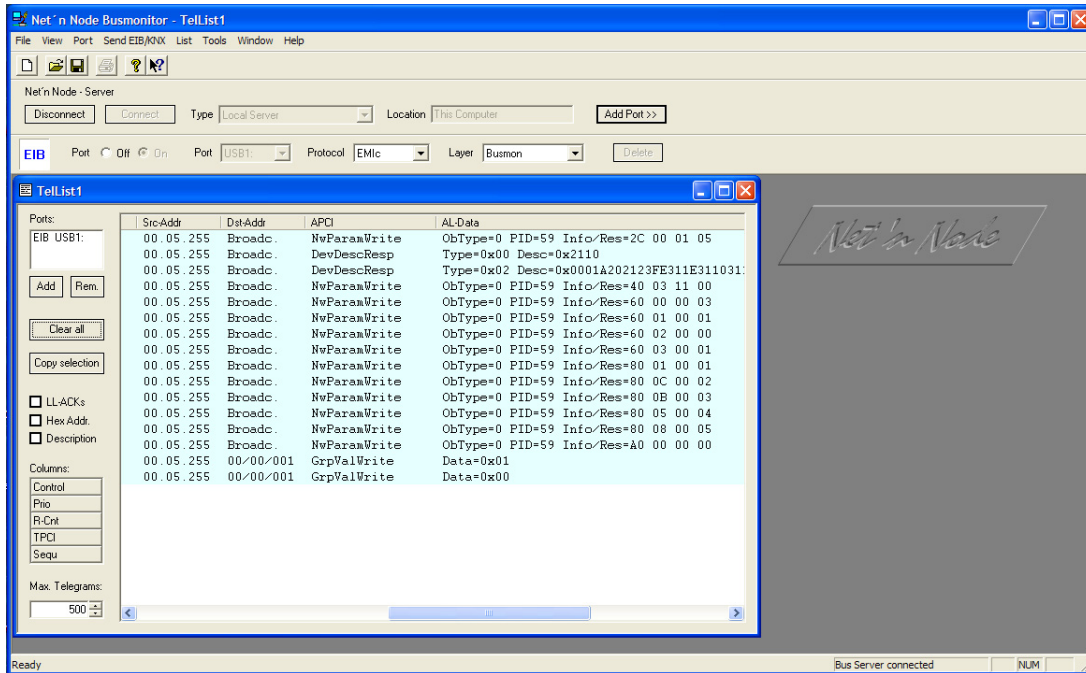

Screenshot of *Net'n Node*

Net'n Node is not only able to receive and interpret RF frames but also offers the possibility to send both runtime and management frames. The display is in cEMI format (part of the KNX standard). A USB interface is available for KNX-RF to access the medium.



USB interface for KNX-RF

7 KNX Certification

The KNX Trademark is a token for quality and interoperability of home and building system engineering products. For KNX-RF the system software as well as the hardware has to be certified. When building a device based on a certified platform, only the application part

needs to be tested to certify the complete device. Further information about KNX certification, test labs and KNX membership is available from:

KNX Association

Bessenveldstraat 5

B-1831 Diegem

BELGIUM

Web: www.knx.org

8 Bibliography

- [1] KNX Association: KNX standard (Version 1.1), Brussels, February 2004; CD-ROM
- [2] Weinzierl, Thomas: KNX-RF: A new Standard for Wireless Networks within Buildings; Proceedings Wireless Congress 2006: Systems & Applications; Munich, 15.11.2006
- [3] Kyselytsya, Yuriy; Weinzierl, Thomas: Implementation of the KNX Standard; Proceedings KNX Scientific Conference 2006, Vienna, 9.11.2006;
- [4] More Information at www.weinzierl.de

WEINZIERL ENGINEERING GMBH

Bahnhofstr. 6

84558 Tyrlaching

Tel. +49 (0) 8623 / 987 98 - 03

Fax +49 (0) 8623 / 987 98 - 09

E-Mail: info@weinzierl.de

Web: www.weinzierl.de

IMPORTANT NOTICE

Texas Instruments Incorporated and its subsidiaries (TI) reserve the right to make corrections, modifications, enhancements, improvements, and other changes to its products and services at any time and to discontinue any product or service without notice. Customers should obtain the latest relevant information before placing orders and should verify that such information is current and complete. All products are sold subject to TI's terms and conditions of sale supplied at the time of order acknowledgment.

TI warrants performance of its hardware products to the specifications applicable at the time of sale in accordance with TI's standard warranty. Testing and other quality control techniques are used to the extent TI deems necessary to support this warranty. Except where mandated by government requirements, testing of all parameters of each product is not necessarily performed.

TI assumes no liability for applications assistance or customer product design. Customers are responsible for their products and applications using TI components. To minimize the risks associated with customer products and applications, customers should provide adequate design and operating safeguards.

TI does not warrant or represent that any license, either express or implied, is granted under any TI patent right, copyright, mask work right, or other TI intellectual property right relating to any combination, machine, or process in which TI products or services are used. Information published by TI regarding third-party products or services does not constitute a license from TI to use such products or services or a warranty or endorsement thereof. Use of such information may require a license from a third party under the patents or other intellectual property of the third party, or a license from TI under the patents or other intellectual property of TI.

Reproduction of TI information in TI data books or data sheets is permissible only if reproduction is without alteration and is accompanied by all associated warranties, conditions, limitations, and notices. Reproduction of this information with alteration is an unfair and deceptive business practice. TI is not responsible or liable for such altered documentation. Information of third parties may be subject to additional restrictions.

Resale of TI products or services with statements different from or beyond the parameters stated by TI for that product or service voids all express and any implied warranties for the associated TI product or service and is an unfair and deceptive business practice. TI is not responsible or liable for any such statements.

TI products are not authorized for use in safety-critical applications (such as life support) where a failure of the TI product would reasonably be expected to cause severe personal injury or death, unless officers of the parties have executed an agreement specifically governing such use. Buyers represent that they have all necessary expertise in the safety and regulatory ramifications of their applications, and acknowledge and agree that they are solely responsible for all legal, regulatory and safety-related requirements concerning their products and any use of TI products in such safety-critical applications, notwithstanding any applications-related information or support that may be provided by TI. Further, Buyers must fully indemnify TI and its representatives against any damages arising out of the use of TI products in such safety-critical applications.

TI products are neither designed nor intended for use in military/aerospace applications or environments unless the TI products are specifically designated by TI as military-grade or "enhanced plastic." Only products designated by TI as military-grade meet military specifications. Buyers acknowledge and agree that any such use of TI products which TI has not designated as military-grade is solely at the Buyer's risk, and that they are solely responsible for compliance with all legal and regulatory requirements in connection with such use.

TI products are neither designed nor intended for use in automotive applications or environments unless the specific TI products are designated by TI as compliant with ISO/TS 16949 requirements. Buyers acknowledge and agree that, if they use any non-designated products in automotive applications, TI will not be responsible for any failure to meet such requirements.

Following are URLs where you can obtain information on other Texas Instruments products and application solutions:

Products

Amplifiers	amplifier.ti.com
Data Converters	dataconverter.ti.com
DSP	dsp.ti.com
Clocks and Timers	www.ti.com/clocks
Interface	interface.ti.com
Logic	logic.ti.com
Power Mgmt	power.ti.com
Microcontrollers	microcontroller.ti.com
RFID	www.ti-rfid.com
RF/IF and ZigBee® Solutions	www.ti.com/lprf

Applications

Audio	www.ti.com/audio
Automotive	www.ti.com/automotive
Broadband	www.ti.com/broadband
Digital Control	www.ti.com/digitalcontrol
Medical	www.ti.com/medical
Military	www.ti.com/military
Optical Networking	www.ti.com/opticalnetwork
Security	www.ti.com/security
Telephony	www.ti.com/telephony
Video & Imaging	www.ti.com/video
Wireless	www.ti.com/wireless

Mailing Address: Texas Instruments, Post Office Box 655303, Dallas, Texas 75265
Copyright © 2008, Texas Instruments Incorporated